

1. DESCRIPTION

MONOBLOC Tensiometer Transducers are designed to reliably and accurately measure strip and web tension in hostile industrial applications such as metals processing lines and paper mills. Applications include both new installations and the retrofitting or upgrading of existing systems.

Tension is measured by sensing the force generated by the deflection of the strip over a sensing roll. MONOBLOC Tensiometer Transducers are designed to mount directly under roll bearing pillow blocks. Strain gages are the measuring elements within the transducer, permitting the use of DC excitation to provide exceptionally fast response to changes in tension.

2. APPLICATIONS

- Metals industry processing lines
- Tandem Cold Mills entry and exit tension measurement
- Single stand cold mills
- Paper industry web tension control

3. COMPETITIVE ADVANTAGES

- Manufactured from single piece high-strength stainless steel forgings to provide mechanical strength, physical integrity and superior corrosion resistance.
- Hermetically sealed against water, steam and mill lubricants.
- Insensitive to forces perpendicular to the sensing direction.
- Excellent linearity through the entire measuring range.
- Full temperature compensation.
- The Monobloc plus KELK signal processor combination has a better than 1.5 millisecond speed of response.
- Easy to install below any suitable roll, with minimum modification to existing support structure. Mounting holes can be custom drilled to suit existing pillow blocks.
- Overload capability of 5x rated capacity without zero shift and 6x without mechanical damage. Application overload ratings up to 10x can be achieved by selecting a higher capacity.
- Deflection along the sensing axis less than 0.1mm (0.004 inches) preventing any loss of accuracy caused by roll movement (change in geometry), minimizing oscillations of the roll assembly.

4. SYSTEM CONFIGURATION

4.1 MILL MOUNTED PARTS

4.1.1 MONOBLOC Tensiometer Transducers

There are two types of MONOBLOC transducers:

Type **N** which measures force normal to the mounting surface.

Type **P** which measures force parallel to the long axis of the mounting surface.

Each model type is insensitive to force applied at right angles to the sensing direction. Both model types are available in six standard sizes (*See Table 1*) as well as custom sizes.

Each transducer is fitted with a standard 6 meter (20 feet) permanently attached four conductor shielded cable. Other lengths are available. The cable terminates in a junction box, supplied separately.

A protective, steel reinforced, oil resistant hydraulic hose assembly encloses the cable.

4.1.2 Junction Box (Option)

The Junction Box provides environmental protection for the termination of the MONOBLOC cable/hydraulic hose.

4.1.3 Interconnecting Cable (Option)

Interconnecting Cable is available from KELK in custom lengths to conduct signals between Junction Box and Electronics.

4.2 ELECTRONICS (Supplied Separately)

MONOBLOC Tensiometer Transducers are designed for use with KELK signal processors models GPA2 or DSP2. Consult KELK for recommendations.

4.3 SCOPE OF SUPPLY

4.3.1 Scope of Supply for each measuring location:

- 2 MONOBLOC Tensiometer Transducers
- 1 Signal Processor, such as KELK GPA2

4.3.2 Options Available

- Custom MONOBLOC cable length
- Junction Box
- Interconnecting Cable
- Locating dowels or keys
- Flange mounting designs for applications where mounting bolts must be inserted from the MONOBLOC side of the frame or bearing support.
- Extended temperature compensation to 150°C (302°F)
- Custom adapter plates for use between MONOBLOCS and existing bearings.

5. SPECIFICATIONS

- 5.1 Model: Designated as M(b)(a)(xxxx)-(yy), where
- M = MONOBLOC
 - b = physical size of MONOBLOC, (see *Table 1*)
 - a = force sensing direction: N (Normal to mounting surface)
P (Parallel to the long axis of mounting surface)
 - xxxx = capacity in kN
 - yy = version number

Example: MDN0036-03 is a 36kN, size 'D', which measures loads normal to the mounting surface.

- 5.2 Capacity: Available from 1 to 300 kilonewtons. (See Table 1)
- 5.3 Excitation Voltage: 25 volts DC or AC maximum
- 5.4 Output: 1.0 millivolt per volt of excitation at rated capacity
- 5.5 Deflection: Less than 0.1mm (0.004 inches) at rated capacity
- 5.6 Overload without zero shift: 500% of rated capacity
- 5.7 Linearity: Within $\pm 0.1\%$ of full scale output.
- 5.8 Hysteresis : Within 0.1% of full scale output.
- 5.9 Repeatability: Within $\pm 0.05\%$ of full scale output.
- 5.10 Thermal Zero Shift: $\pm 0.008\%$ (80 parts per million) of full scale output per °C over the normal compensated range from 20°C to 100°C (68°F to 212°).
- 5.11 Operating Temperature: 0°C to 170°C (32°F to 340°F)
- 5.12 Weight: Weight in kilograms = $L * W * H * 7.833 \cdot 10^{-6}$ (see Table 1 millimeter dimensions). Weight in pounds = $L * W * H * 0.283$ (see Table 1 inch dimensions)

6. DIMENSIONS

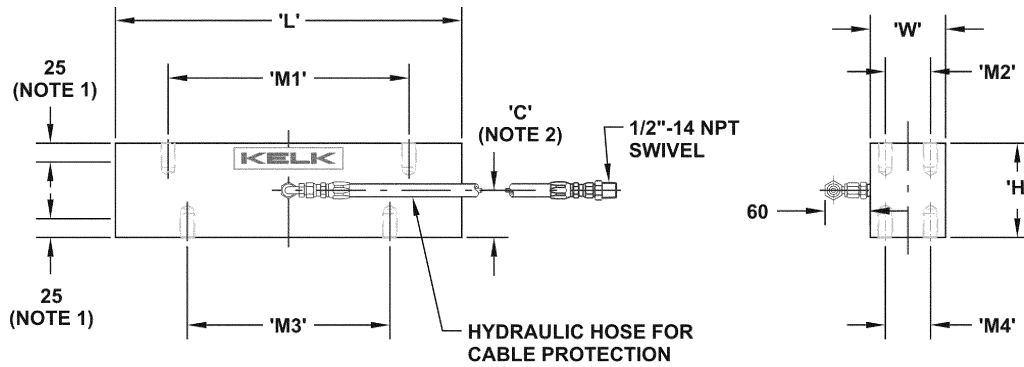

NOTES:

1. FIXED AREA MAY BE RECESSED OR RESTRAINED;
AREA ABOVE IS SENSING AND MUST BE FREE TO AVOID LOAD SHUNTING.

2. 'N' SENSING MODELS 'C' = H / 2
'P' SENSING MODELS 'C' = 20mm [3/4"]

Table 1

Model Series	Sensing Direction	L mm (in)	W mm (in)	H mm (in)	Available Capacity		Recommended Thread Hole Sizes Metric (Imperial)	Default Mounting Bolt Pattern				Weight Kg (lb)
					Min kN	Max kN		M1 mm (in)	M2 mm (in)	M3 mm (in)	M4 mm (in)	
MA	P or N	250 (9.84)	89 (3.50)	125 (4.92)	2	24	<16kN 4 @ M12 (1/2") x 18DP >16kN 4 @ M16 (5/8") x 24DP	160 (6.30)	55 (2.17)	180 (7.09)	55 (2.17)	22 (48)
MB	P or N	300 (11.81)	89 (3.50)	125 (4.92)	2	32	<16kN 4 @ M12 (1/2") x 18DP >16kN 4 @ M16 (5/8") x 24DP	180 (7.09)	55 (2.17)	220 (8.66)	55 (2.17)	26 (58)
MC	P or N	375 (14.76)	100 (3.94)	125 (4.92)	4	60	<32kN 4 @ M16 (5/8") x 24DP >32kN 4 @ M20 (3/4") x 27DP	240 (9.45)	60 (2.36)	280 (11.02)	60 (2.36)	37 (81)
MD	P or N	460 (18.11)	100 (3.94)	125 (4.92)	4	80	<48kN 4 @ M20 (3/4") x 27DP >48kN 4 @ M24 (1") x 32DP	300 (11.81)	60 (2.36)	350 (13.78)	60 (2.36)	45 (100)
ME	P or N	508 (20.00)	114 (4.49)	170 (6.69)	16	150	<100kN 4 @ M24 (1") x 32DP >100kN 4 @ M30 (1 1/4") x 40DP	320 (12.60)	70 (2.76)	380 (14.96)	70 (2.76)	77 (170)
MF	P or N	560 (22.05)	127 (5.00)	200 (7.87)	16	250	<100kN 4 @ M24 (1") x 32DP >100kN 4 @ M30 (1 1/4") x 40DP	380 (14.96)	75 (2.95)	440 (17.32)	75 (2.95)	112 (246)
MQ	P or N	CUSTOM SIZES			1	300	CAPACITY DEPENDENT					

NOTE: Mounting holes can be custom drilled to meet customer's requirement

George Kelk Corporation, Head Office, 48 Lesmill Road, Toronto, Ontario, M3B 2T5, Canada
Tel: +1-416-445-5850 • Fax: +1-416-445-5972 • E-mail: kelkcorp@kelk.com • Website: www.kelk.com

Description and Specifications subject to change without notice
Printed in Canada